



QPM : Wellness help applications

QPM wellness measurement provides answers to basic questions such as:

- What is my current physical, mental and emotional status?
- What do I need to improve my well-being?

The QPM measurement system starts with the body and can:

- analyze your current status
- prescribe
 - exercises for body and mind
 - the most appropriate care
 - health supplements and foods

The wellness help applications are intended for professionals in a variety of sectors.

Those sectors include fitness centers, spas, nutritionists, laboratories, longevity clinics and more.

Regarding nutrition, QPM identifies the foods to avoid and those best suited to the organism.

QPM provides information on oxidative stress levels and their consequences for the individual.

A single machine for several applications.

A single measurement for several interpretational readings.

QPM SPA L and XL
QPM WELLNESS
QPM COSMETOLOGY
QPM DIETETICS
QPM MICRO NUTRITION
QPM LONGEVITY





QPM column technical datasheet

1. Technical datasheet

- 1 12-inch touch screen
- 1 PC running on windows operating system
- 1 QPM box
- 4 fixed electrodes
- 6 cables
- 1 unit on casters

2. Physical characteristics

- Dimensions : Length 476 mm x Width 505 mm x Height 1280 mm
- Overall weight of the apparatus : 36 Kg
- Conditioned in a shell for transportation

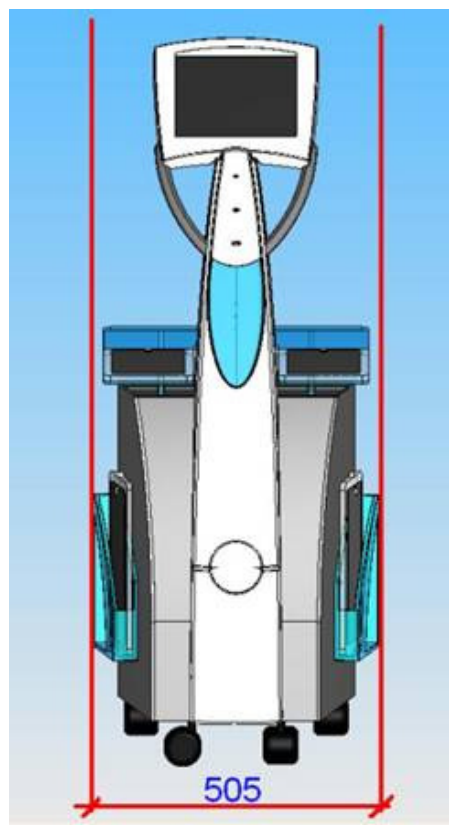
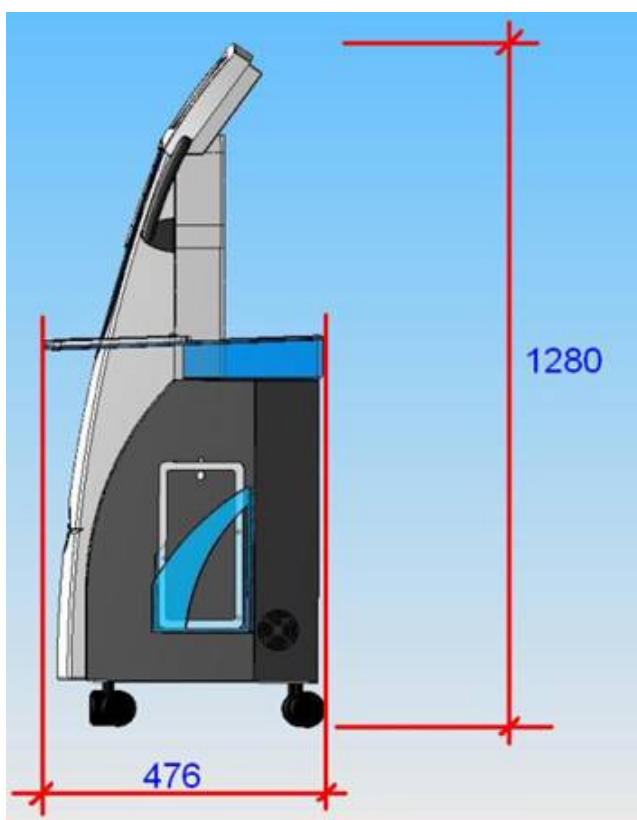

CONTACT

Patrick VISIER - Tél. 00 33 6 11 19 82 39
patrick.visier@quanticpotential.com

QPM - 24 rue Morère - 75014 PARIS - Tél. 00 33 1 45 41 86 01



www.quanticpotential.com